

連結盤

- ◆ 各種鼻端規格，干島連結盤均能選配使用。
- ◆ "Chandex" mounting plates are available to any kinds of spindle noses.

尺寸圖 » Dimensions



圖-1 Fig.1

圖-2 Fig.2

圖-3 Fig.3

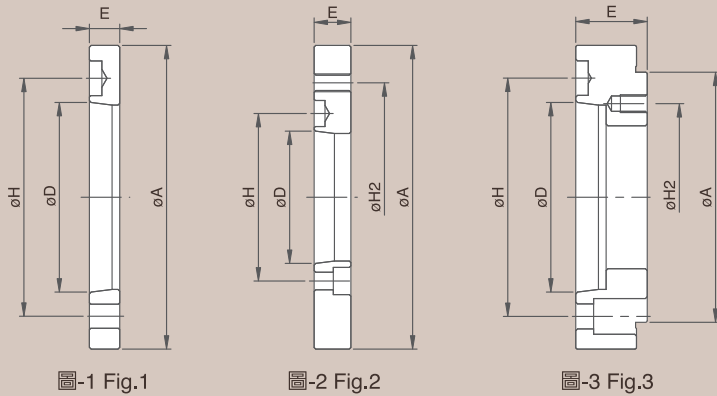

圖-1 Fig.1



圖-2 Fig.2



圖-3 Fig.3

規格表 » Specifications

單位/UNIT:mm

型式/規格 MODEL /SPEC.	鼻端番號 Nose of Spindle D	A	H	H2	E	參考圖 Reference Drawing
T005A ₂ 4	A ₂ 4	110	82.6	--	20	圖-1 fig.1
T006A ₂ 5	A ₂ 5	140	104.8	--	15	圖-1 fig.1
T008A ₂ 6	A ₂ 6	170	133.4	--	17	圖-1 fig.1
T010A ₂ 8	A ₂ 8	220	171.4	--	18	圖-1 fig.1
T012A ₂ 8	A ₂ 8	220	171.4	--	18	圖-1 fig.1
T015A ₂ 11	A ₂ 11	300	235	--	22	圖-1 fig.1
T018A ₂ 11	A ₂ 11	300	235	--	22	圖-1 fig.1
型式/規格 MODEL /SPEC.	鼻端番號 Nose of Spindle D	A	H	H2	E	參考圖 Reference Drawing
T005A ₂ 5	A ₂ 5	110	104.8	82.6	45	圖-3 fig.3
T006A ₂ 4	A ₂ 4	140	82.6	104.8	20	圖-2 fig.2
T006A ₂ 6	A ₂ 6	140	133.4	104.8	40	圖-3 fig.3
T008A ₂ 8	A ₂ 8	170	171.4	133.4	45	圖-3 fig.3
T008A ₂ 5	A ₂ 5	170	104.8	133.4	23	圖-2 fig.2
T010A ₂ 6	A ₂ 6	220	133.4	171.4	28	圖-2 fig.2
T012A ₂ 11	A ₂ 11	220	235	171.4	54	圖-3 fig.3
T015A ₂ 8	A ₂ 8	300	171.4	235	33	圖-2 fig.2